

COMPRESSIVE STRENGTH EVALUATION OF CONCRETE MASONRY

TEK 18-1A

Quality Assurance and Testing (2004)

Keywords: ASTM standards, compressive strength, prism testing, specified compressive strength of masonry (f'_m) testing, unit strength method.

INTRODUCTION

Structural performance of concrete masonry is largely dependent upon three key criteria:

- the engineering rationale incorporated into the design of the structure;
- the physical characteristics of the materials used in the construction of the structure (i.e., the masonry units, grout, mortar, and reinforcement); and
- the quality of the construction used in assembling these components.

The first step in the design of any engineered masonry structure is the determination of anticipated service loads. Once these loads are established, the required strength of the masonry can be determined. This required strength is designated f'_m or specified compressive strength. It is used throughout the design in accordance with the appropriate masonry code to establish allowable stresses for elements. It should be stressed that the specified compressive strength of the masonry is related to but *not* equal to the tested compressive strength of the masonry.

To ensure that a safe and functional structure is being constructed that will equal or exceed the intended service life, measures must be taken to verify that the composite compressive strength of the materials used in construction meet or exceed the specified compressive strength of the masonry. Compliance with the specified compressive strength is verified by one of two methods: the unit strength method or the prism test method. These two methods are referenced in masonry design codes (ref. 1), specifications (ref. 2), and standards (ref. 3) as rational procedures for verifying masonry compressive strength.

UNIT STRENGTH METHOD

The unit strength method is often considered the least

Table 1—Compressive Strength of Masonry Based on the Compressive Strength of Concrete Units and Type of Mortar Used in Construction¹ (ref. 2)

Net area compressive strength of concrete masonry units, psi (MPa)		Net area compressive strength of masonry ² , f'_m psi (MPa)
Type M or S mortar	Type N mortar	
1,250 (8.61)	1,300 (8.96)	1,000 (6.89)
1,575 (10.9)	1,725 (11.9)	1,250 (8.61)
1,900 (13.1)	2,150 (14.9)	1,500 (10.3)
2,350 (16.2)	2,600 (17.9)	1,750 (12.1)
2,800 (19.3)	3,050 (21.0)	2,000 (13.8)
3,275 (22.6)	3,550 (24.5)	2,250 (15.5)
3,750 (25.8)	4,050 (27.9)	2,500 (17.2)
4,275 (29.5)	4,650 (32.0)	2,750 (18.9)
4,800 (33.1)	5,250 (36.2)	3,000 (20.7)

¹ Linear interpolation between shown values is permitted.

² For units less than 4 in. (102 mm) in height, use 85% of the values listed.

expensive and most convenient of the two methods. However, the unit strength method also yields *more conservative* results when compared to the prism test method especially at the higher range of masonry unit strengths.

Compliance with f'_m by the unit strength method is based on the net area compressive strength of the units and the type of mortar used. The compressive strength of the masonry assemblage is then established in accordance with Table 1. Table 1 is based on criteria from *Specification for Masonry Structures* (ref. 2), Section 1.4.B.2.b. Similar provisions are contained in Section 2105.2.2.1.2 of the *International Building Code* (ref. 4).

According to both of these documents, use of the unit strength method requires the following:

- Masonry units must be sampled and tested in accor-

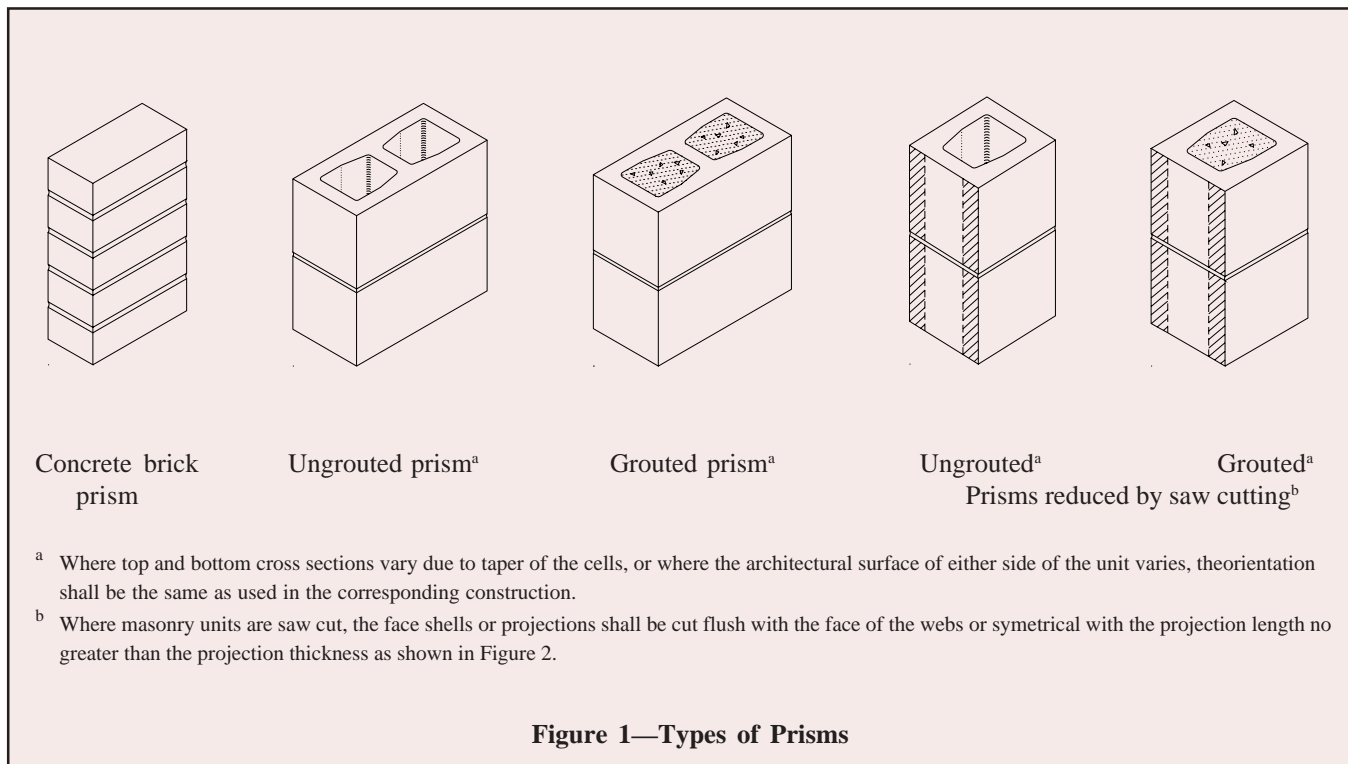

Figure 1—Types of Prisms

dance with ASTM C 140 *Standard Test Method for Sampling and Testing Concrete Masonry Units and Related Units* (ref. 5) and meet the requirements of either ASTM C 55 *Standard Specification for Concrete Brick* (ref. 6) or ASTM C 90 *Standard Specification for Loadbearing Concrete Masonry Units* (ref. 7).

- Thickness of bed joints used in construction must not exceed $\frac{5}{8}$ in. (15.9 mm).• If grouted masonry is used in construction, the grout must meet either the proportion or the property specification of ASTM C 476 *Standard Specification for Grout for Masonry* (ref. 8). When property specifications are used, the compressive strength of the grout is determined in accordance with ASTM C 1019 *Standard Test Method for Sampling and Testing Grout* (ref. 9).
- Mortar must comply with requirements of ASTM C 270 *Standard Specification for Mortar for Unit Masonry* (ref. 10) or ASTM C 1329 *Standard Specification for Mortar Cement* (ref. 12).

Since all concrete masonry units complying with ASTM C 90 (ref. 7) have compressive strengths exceeding 1,900 psi (13.1 MPa), any C 90 unit that is used with Type M or S mortar can be used for projects that have f'_m values up to 1,500 psi (10.3 MPa) by the unit strength method. If used with Type N mortar, any C 90 unit can be used for projects having f'_m values up to 1,350 psi (9.3 MPa). Conversely, if the concrete masonry units have compressive strengths of 2,800 psi (19.3 MPa), then the maximum f'_m used in design would be 2,000 psi (13.8 MPa) if Type M or S mortar were used. Similarly, if 3,050 psi (21.0 MPa) concrete masonry were used in conjunc-

tion with Type N mortar, the maximum f'_m that could be used in design would also be 2,000 psi (13.8 MPa). Note that per footnote 2 of Table 1, compressive strength of masonry values must be multiplied by 85% when the unit strength is established on units less than 4 in. (102 mm) in height. When higher strength masonry materials are specified, it usually is more cost effective to utilize the prism test method to demonstrate compliance with f'_m due to the level of conservatism inherent in the unit strength method.

PRISM TEST METHOD

The prism test method determines the actual compressive strength of a masonry prism. When documenting compliance with f'_m , prisms are typically tested at an age of 28 days but may have a different designated testing age. The prism test method is referenced in *Specification for Masonry Structures*, Section 1.4.B.3 (ref. 2), the *International Building Code*, Section 2105.2.2.2 (ref. 4), and contained within ASTM C 1314 *Standard Test Method for Compressive Strength of Masonry Prisms* (ref. 3).

Prism Construction

Construct masonry prisms using units representative of those being used in the construction and in a location where they can remain undisturbed for no less than 48 hours. One set of prisms (containing three individual prisms) shall be constructed for each combination of materials and each testing age for which the compressive strength is to be determined. Units shall be laid in stack bond on a full mortar bed using mortar representative of

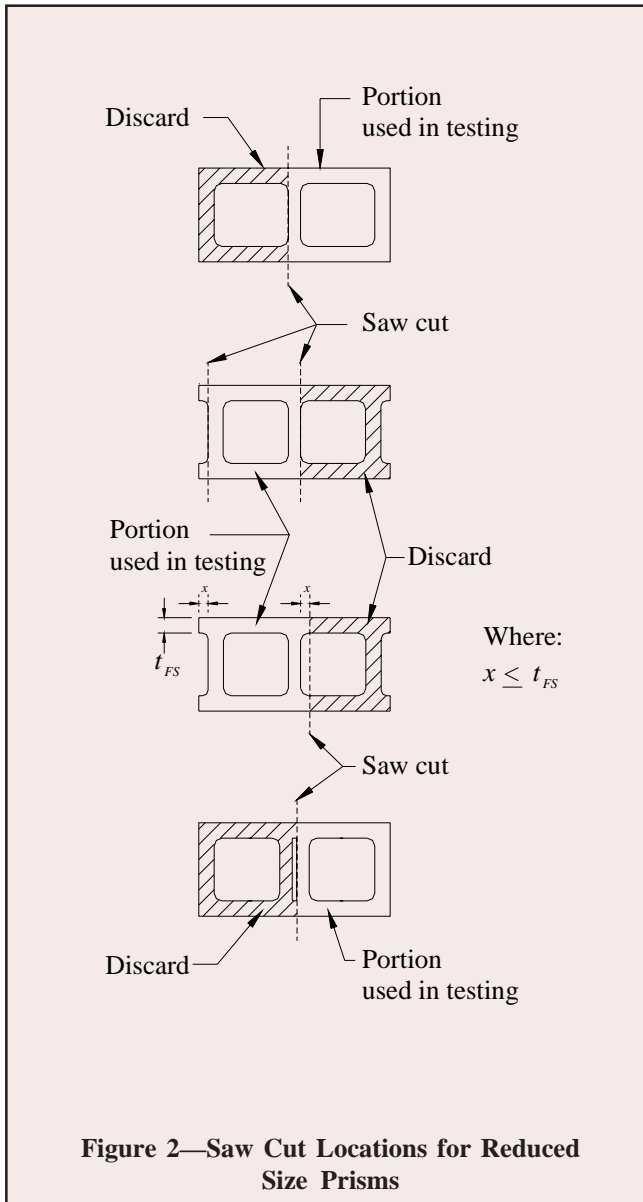

that used in the corresponding construction. All units used in the prisms must be of the same configuration and oriented in the same way so that webs and face shells are aligned. Mortar joints shall be cut flush regardless of the type of tooling used in construction. Prisms composed of units that contain closed cells shall have at least one complete cell with one full-width cross web on either end. Immediately following construction of the prisms, seal each prism in a moisture-tight bag. Different prism configurations are shown in Figure 1.

The prism test method requires prisms to be cured in sealed plastic bags to ensure uniform hydration of the mortar and the grout if used. Under actual field conditions it may require longer periods for hydration and the corresponding strengths to be achieved. Curing prisms in sealed plastic bags results in measured strengths which are representative of those exhibited by the masonry throughout the life of the structure. Bag curing also

provides a uniform and repeatable testing procedure.

Where the corresponding construction is to be grouted solid, grout solid each prism using grout representative of that being used in the corresponding construction. Grouting of prisms shall occur not less than 24 hours and not more than 48 hours following the construction of the prisms. Consolidate and reconsolidate the grout in each prism using procedures representative of those used in the corresponding construction, ensuring that the top of the grout when hardened is level with the top of the prism. Immediately following grouting of prisms, reseal the moisture-tight bag around each prism. If the corresponding construction is to be partially grouted, construct two sets of prisms – grouting one set while leaving the other set ungrouted.

Since masonry prisms can be heavy, especially for solidly grouted prisms, it often proves effective to construct prisms using half-length units. The only criteria for constructing prisms out of reduced-sized units is that hollow units contain fully closed cells, the cross section is as symmetrical as possible, and the length is not less than 4 in. (102 mm). As a result, handling, transporting, capping, and testing the reduced sized prisms is easier, resulting in a reduced potential for damage to the prisms. These reduced-length prisms also reduce required plate thicknesses for compression machines and typically result in higher and more accurate assessments of masonry strengths.

Transporting Prisms

Since mishandling prisms during transporting from the job site to the testing facility can have significant detrimental effects on the tested compressive strength of prisms, extreme care should be taken to protect against damage during transport. Prior to transporting prisms, strap or clamp each prism as shown in Figure 3. Tightly clamping or strapping plywood to the top and bottom of a prism prevents the mortar joint from being subjected to tensile stresses during handling.

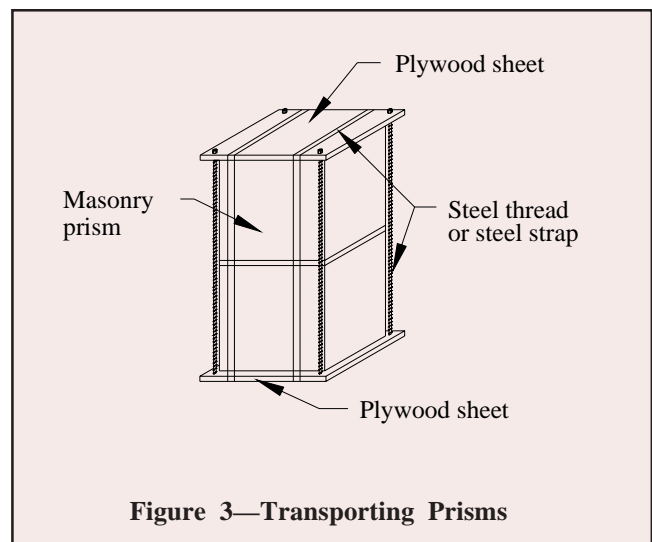

Curing Prisms

As previously stated, each prism is constructed in a moisture-tight bag (Figure 4) large enough to enclose and seal the completed prism. Make sure that the bags have adequate thickness to prevent tearing. Thickness of 2 mils (0.0051 mm) or greater has been found to work well. After the initial 48 hours of job site curing, carefully move each prism to a location where the temperature is maintained at 75 ± 15 °F (24 ± 8 °C).

Prism Net Cross-Sectional Area

Determination of net cross-sectional area used in calculating compressive strength of a prism will vary depending on whether prisms are grouted or not. For ungrouted prisms, the cross-sectional area is the net cross-sectional area determined in accordance with ASTM C 140. When reduced sized units are used to construct prisms, the net cross-sectional area is based on the reduced sized units. Therefore three concrete masonry units of similar dimensions and identical configuration as those used in the prism should be submitted to the testing laboratory along with the prisms. When testing fully grouted prisms, net cross-sectional area is determined by multiplying the length and width of the prism per ASTM C 1314.

Testing Prisms

Two days prior to the 28 day time interval or the designated testing time, remove each prism from the moisture tight bag. Prism age is determined from the time of laying units for ungrouted prisms, and from the time of grouting for grouted prisms.

To provide a uniform and smooth bearing surface, prisms are capped with either a sulfur or high-strength gypsum compound in accordance with ASTM C 1552 *Standard Practice for Capping Concrete Masonry Units, Related Units and Masonry Prisms for Compression Testing* (ref. 12). For sulfur capping materials, the mixtures are to consist of 40 to 60 percent sulfur with the rest being ground fire clay or other suitable material passing a No. 100 (150- μ m) sieve. The average thickness of the sulfur cap is not to exceed $\frac{1}{4}$ in. (6.4 mm). For high strength gypsum capping materials, the compressive strength of the plaster is to be at least 3500 psi (24.1 MPa) when tested in 2 in. (51 mm) cubes at two hours. The average thickness of the gypsum cap is not to exceed $\frac{1}{8}$ in. (3.2 mm). No other capping materials are allowed. Caps are to be aged for at least 2 hours before testing the specimens, regardless of the type of capping material. Capping plates of adequate stiffness and smoothness are critical to achieving accurate results. Machined steel plates of 1 in. (25.4 mm) minimum thickness are required for the base. Glass plates not less than $\frac{1}{2}$ in. (13 mm) in thickness may be used as a wearing surface to protect the plates. The casting plate must be plane within 0.003 in. in 16 in. (0.075 mm in 400 mm) and free of gouges, grooves, and indentations greater than 0.010 in. (0.25 mm) deep or greater than 0.05 in² (32 mm²).



Figure 4—Constructing a Half-Length Prism in a Plastic Bag

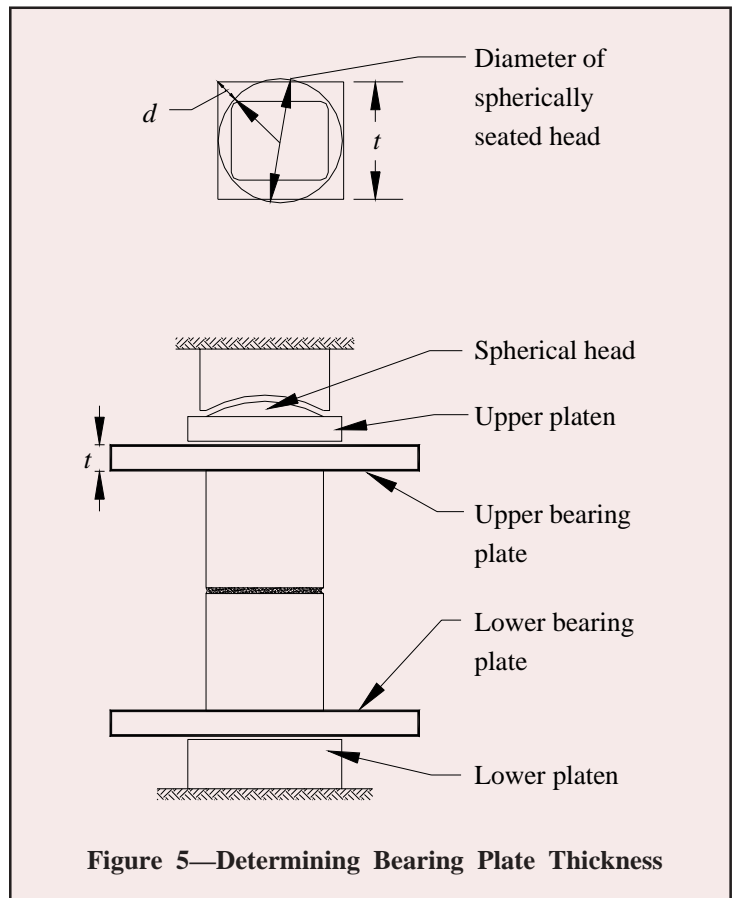

One of the most common oversights in testing masonry prisms is compliance with the established requirements for the testing machine itself. The testing machine is required to have a spherically seated head with a minimum 6 in. (150 mm) diameter and capable of rotating in any direction. The spherically seated head is then attached to a single thickness steel bearing plate having a width and length at least $\frac{1}{4}$ in. (6.4 mm) greater than the length and width of the prism being tested. The required thickness of the steel bearing plate depends on the diameter of the spherically seated head and the width and length of the prism being tested. The thickness of the steel bearing plate shall equal or exceed the maximum distance from the outside of the spherically seated head to the outmost corner of the prism – designated d in Figure 5. Failure to provide the required minimum bearing plate thickness decreases the measured compressive strength of the prism. It is also required that the bearing faces of the plates have a Rockwell hardness of at least HRC 60 (BHN 620).

The last step prior to testing a prism in compression is determining the center of mass of the prism. The center of mass of a prism can be thought of as the point on the cross-section of a prism where it could physically balance on the tip of a point. The prism is then centered within the test machine such that the center of mass coincides with the center of thrust (which coincides with the center of the spherically seated head). Failure to line up the center of mass with the center of thrust results in a nonuniform application of load and therefore, decreased compressive strengths. For prisms having symmetric cross-sections, the mass centroid coincides with the geometric centroid – or the center of the prism as measured with a ruler. For prisms that are nonsymmetrical about an axis, the location of that axis can be determined by balancing the masonry unit on a knife edge or a metal rod placed parallel to that axis. If a metal rod is used, the rod must be straight, cylindrical (able to roll freely on a flat surface), have a diameter of not less than $\frac{1}{4}$ in. (6.4 mm) and not more than $\frac{3}{4}$ in. (19.1 mm), and it must be longer than the specimen. Once determined, the centroidal axis can be marked on the end of the prism.

Since the ratio of height to least lateral dimension – designated the aspect ratio or h/t – of the prism can significantly affect the load carrying capacity of the masonry prism, ASTM C 1314 contains correction factors for prisms having different aspect ratios as outlined in Table 3.

To use the values in Table 3, simply multiply the measured compressive strength of the prism by the correction factor corresponding to the aspect ratio for that prism. Correction factors shown in Table 3 can be linearly interpolated between values, but cannot be extrapolated for aspect ratios less than 1.3 or greater than 5.0.

Example

An example on how to determine the necessary bearing plate thickness follows:

Diameter of spherically seated head = 8 in. (203 mm)

Width of Prism = 7.64 in. (194 mm)

Height of Prism = 15.66 in. (398 mm)

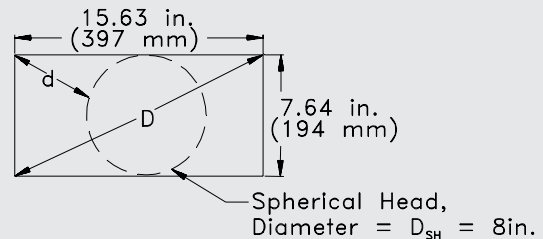

$$D = \sqrt{(7.64)^2 + (15.63)^2}$$

$$= 17.40 \text{ in. (442 mm)}$$

$$d = \frac{D - D_{SH}}{2} = \frac{17.40 - 8}{2} = 4.70 \text{ in. (119 mm)}$$

Length of Prism = 15.63 in. (397 mm)

Therefore, the thickness of the bearing plate T must equal or exceed 4.70 in. (119 mm). However, if the prism was constructed using reduced-sized units, then;

Length of Prism = 7.65 in. (194 mm)

$$D = \sqrt{(7.65)^2 + (7.64)^2} = 10.81 \text{ in. (275 mm)}$$

$$d = \frac{10.81 - 8}{2} = 1.41 \text{ in. (35.7 mm)}$$

Width of Prism = 7.64 in. (194 mm)

As a result, the required thickness of the bearing plate T is significantly reduced from 4.70 in. (119 mm) to 1.41 in. (35.7 mm).

Table 3 – Prism Aspect Ratio Correction Factors (ref. 5)

h/t	1.3	1.5	2.0	2.5	3.0	4.0	5.0
Correction Factor	0.75	0.86	1.0	1.04	1.07	1.15	1.22

REFERENCES

1. *Building Code Requirements for Masonry Structures*, ACI 530-02/ASCE 5-02/TMS 402-02. Reported by the Masonry Standards Joint Committee, 2002.
2. *Specifications for Masonry Structures*, ACI 530.1-02/ASCE 6-02/TMS 602-02. Reported by the Masonry Standards Joint Committee, 2002.
3. *Standard Test Method for Compressive Strength of Masonry Prisms*, ASTM C 1314-03b. ASTM International, 2003.
4. *International Building Code*, International Code Council, 2003.
5. *Standard Test Methods of Sampling and Testing Concrete Masonry Units and Related Units*, ASTM C 140-03. ASTM International, 2003.
6. *Standard Specification for Concrete Brick*, ASTM C 55-03. ASTM International, 2003.
7. *Standard Specification for Loadbearing Concrete Masonry Units*, ASTM C 90-03. ASTM International, 2003.
8. *Standard Specification for Grout for Masonry*, ASTM C 476-02. ASTM International, 2002.
9. *Standard Test Method for Sampling and Testing Grout*, ASTM C 1019-03. ASTM International, 2003.
10. *Standard Specification for Mortar for Unit Masonry*, ASTM C 270-03b. ASTM International, 2003.
11. *Standard Specification for Mortar Cement*, ASTM C 1329-04. ASTM International, 2004.
12. *Standard Practice for Capping Concrete Masonry Units, Related Units and Masonry Prisms for Compression Testing*, ASTM 1552-03a. ASTM International, 2003.