

National Concrete Masonry Association  
 an information series from the national authority on concrete masonry technology

## BLAST AND BULLET RESISTANT CONCRETE MASONRY BUILDINGS

**TEK 14-21**  
 Structural (1998)

**Keywords:** blast resistance, bullet resistance, glass unit masonry, lateral loads, reinforced concrete masonry, seismic design

### INTRODUCTION

Concrete masonry has long been considered an excellent material for building “secure” structures – from the backyard bomb shelters of the 1950s, to the high security prisons and seismic resistant buildings of today. In recent years, protection from terrorist attacks has become a higher priority for many buildings.

While the type and size of a terrorist attack cannot be predicted, guidelines for improving building performance are available. The mass of concrete masonry is beneficial for blast resistance. Masonry walls also protect against ballistics and shrapnel (flying debris from the bomb). Properly designed concrete masonry and glass masonry products provide protection for people, essential facilities, computers, and security systems.

### BLAST RESISTANCE

In recent years, more non-military buildings, particularly federal buildings, are considering protection from terrorist-type attacks as part of building security. This TEK presents a brief overview of some of the main considerations in designing blast resistant structures. For final design, more detailed guidance is available in the cited references.

#### Blast Loads

Equations have been derived to quantify blast intensity including one by Brode (ref. 4) shown as Equation 1.

$$P_o = \frac{35.6(W_{TNT})^{1/3}}{X} + \frac{134(W_{TNT})^{2/3}}{X^2} + \frac{1359W_{TNT}}{X^3} - 0.2756 \quad (\text{Eq. 1})$$

$$\left[ P_o = \frac{97.5(W_{TNT})^{1/3}}{X} + \frac{145.5(W_{TNT})^{2/3}}{X^2} + \frac{585W_{TNT}}{X^3} - 1.9 \right] \quad (\text{metric})$$

Where:  $1.4 < P_o < 145$  psi ( $10 < P_o < 1000$  kPa)

$P_o$  = initial blast pressure at distance "X", psi (kPa)

$W_{TNT}$  = mass of TNT used in explosion, lbs (kg)

X = distance from the origin of the blast, ft (m)

This equation quantifies the overpressure in an unconfined setting. These pressures may be appropriate for designing the roof, sidewalls, and rear walls of the building. However for the side facing the blast, the front part of the blast wave is reflected off the building surface back into the wave effectively magnifying the pressure. Therefore, depending upon the

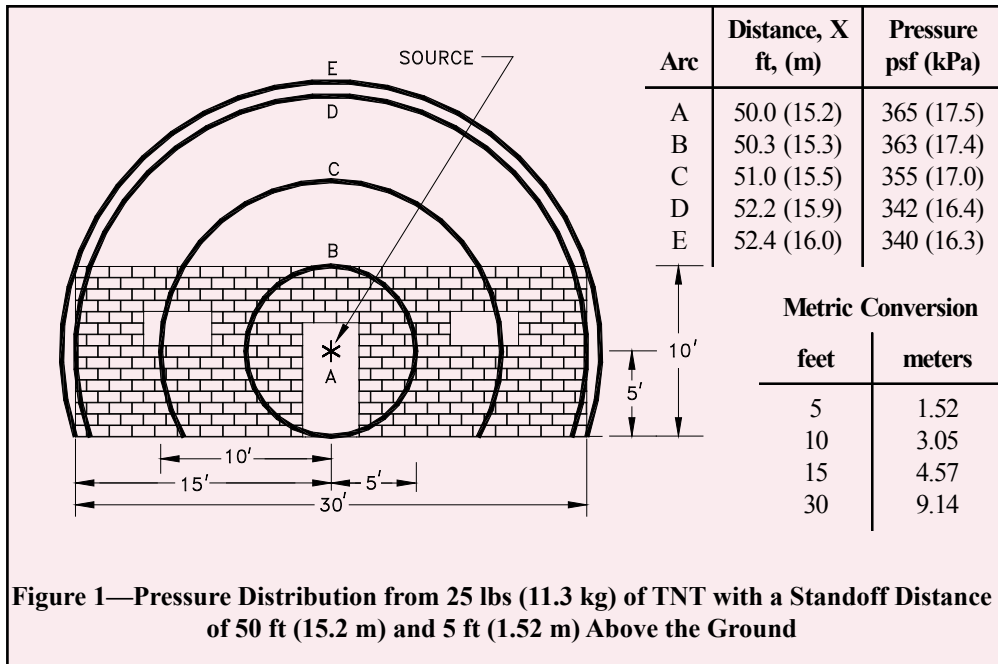

**Figure 1—Pressure Distribution from 25 lbs (11.3 kg) of TNT with a Standoff Distance of 50 ft (15.2 m) and 5 ft (1.52 m) Above the Ground**

configuration and the design parameters, structural elements facing a blast may require higher design pressures than those given by Equation 1 and shown in Figure 1.

Blast loads also are unique in that the peak load lasts only a fraction of a second (generally measured in milliseconds) and the intensity of the load can be several orders of magnitude larger than conventional design loads due to wind or seismic events - see Figure 1. In addition, blast loads cause load reversals described as follows: First, overpressure (higher than atmospheric) resulting from the violent expansion of hot gases produces a layer of compressed air radiating from the source - the blast wave. Almost instantaneously, underpressure (lower than atmospheric) follows resulting in a rush of air back to the source to fill the void left by the suddenly cooled superheated air.

Because of the unpredictability of the blast intensity due to variations in the distance to the source and size of charge used, the most common blast design philosophies recognize that protection is not an absolute. The goal is not necessarily to withstand a blast, but rather to limit the extent of collapse, minimize loss of life, and facilitate evacuation and rescue. Casualties near the blast may be unavoidable, but preventing progressive collapse of the building reduces further fatalities. The design process should include a risk assessment to help determine what level of damage or potential injury is acceptable, considering public access to the building, aesthetics, and economics.

### **Building Standoff Distance**

The distance between the point of detonation and the target, known as standoff distance, is typically considered the most important design parameter for blast resistance for the simple reason that an increase in standoff distance results in a marked decrease in load. For instance as shown in Figure 1, 25 lbs (11.3 kg) of TNT at a standoff distance of 50 ft (15.2 m) produces a blast pressure of 365 psf (17.5 kPa) at Point A. If the standoff distance is increased to 100 ft (30.5 m) the pressure is reduced to 132 psf (6.32 kPa). Conversely, if the standoff distance were reduced to 30 ft (9.1 m), the blast pressure increases to 824 psf (150 kPa). Larger standoff distances also produce more uniform pressure distributions on the structure.

Unfortunately, a large, or even moderate, standoff distance is not always feasible due to site conditions, particularly in urban areas. In these cases, vehicle barriers are often used to keep vehicles off sidewalks and adjacent plaza areas. Materials such as concrete masonry can provide tough barriers that also enhance the streetscape. For example, concrete masonry units or segmental retaining wall units can be used to construct large planters, enhancing security while providing a small green space.

### **Blast Design Guidelines**

The General Services Administration's (GSA) *Security Design Criteria* provides specific criteria for the design of structures to resist blast loading. However, it is available only to federal agencies with a specific need of the information and to design firms under contract for a government facility requir-

ing security enhancements. The goals of the publication are to provide protection for occupants, preserve the character of a free and accessible government, and provide enough structural integrity to allow safe evacuation. The guidelines recognize, however, that buildings can not be bomb shelters – they need to provide a pleasant work environment and complement the surrounding community.

Several sets of guidelines available to the public have been developed in recent years, primarily in response to the bombing of the Alfred P. Murrah Building in Oklahoma City. *Vulnerability Assessment of Federal Buildings* (ref. 10), classifies Federal buildings into five categories based on building size, number of employees, and amount of public access required. For each building category, the report presents a range of security options for consideration.

### **Blast Resistant Structural Systems**

The overriding design philosophy for blast resistant structural systems is to prevent progressive collapse of a structure subjected to a blast load. Structural redundancies should be provided to carry additional loads that may be imposed after a bomb attack. For example, beams, girders, and columns should be detailed to carry the loads of damaged slabs or columns. *The Oklahoma City Bombing: Improving Building Performance Through Multi-Hazard Mitigation* (ref. 6) recommends the use of one of the following structural systems for seismic and/or blast resistance: compartmentalized building, special moment resisting frames, or dual systems which are a combination of the two. These systems provide the mass and toughness necessary to reduce the effects of extreme overloads on buildings, and have typically shown good earthquake resistance.

As the name suggests, compartmentalized buildings are composed of structural “compartments,” which can act somewhat independently. Reinforced structural walls are typically used to provide structural integrity in case part of the building is damaged, thus preventing progressive collapse. The design results in a stiff, massive structure capable of withstanding significant loads. Concrete masonry is well suited to compartmentalized buildings. In fact, masonry shear wall structures designed to current standards have outperformed frame systems in limiting damage from earthquakes and hurricanes. *Concrete Masonry Shear Walls* (ref. 2) provides more detailed design information.

Special moment resisting frames rely on detailing the building joints so that elements adjacent to the damage will continue to function as designed. Hence, damage is prevented from spreading. Detailing requirements are thorough and restrictive to help ensure adequate protection. The design results in a relatively flexible structure that can withstand significant deformation without failure. In buildings designed as special moment resisting frames, concrete masonry is often used as infill between the frames, providing in-plane shear transfer, thereby stiffening the frame. Unlike compartmentalized buildings, special moment resisting frames can provide large open spaces that may be more desirable for some building types.

Dual systems make use of two or more structural systems in combination to resist seismic or blast loads. For example,

a large office building may have a large atrium or other open area at the front. This building may utilize a special moment frame at the front of the building and a shear wall for the back. Dual systems are subjected to rigorous design requirements to ensure structural compatibility between the systems used. For instance, in the example above, the design must adequately account for the differential movement between the flexible moment frame and the stiff shear wall.

The Federal Emergency Management Agency /American Society of Civil Engineers report on the Murrah building (ref. 6) states that buildings currently designed and detailed to resist seismic events will provide some measure of blast resistance. Seismic design requirements are included in the 1994 edition of NEHRP (National Earthquake Hazard Reduction Program) *Recommended Provisions for Seismic Regulations for New Buildings* (ref. 5). NEHRP requires that walls in the highest seismic categories contain minimum areas of both the horizontal and vertical reinforcement of at least 0.007 times the gross cross-sectional area of the wall. It also requires the sum of the horizontal and vertical reinforcement areas to be at least 0.02 times the gross-cross-sectional area of the wall. In addition, minimum reinforcement must be placed in certain areas of the wall where stress concentrations may exist as indicated in Figure 2. Additional seismic detailing requirements are included in *Seismic Design Provisions for Masonry Structures* (ref. 9).

### General Blast-Resistant Design Considerations

In addition to the structure types described above, the following general design considerations are often recommended for blast-resistant buildings (refs. 3 and 4). This is by no means a complete list, but rather highlights some of the provisions applicable to the building structure and skin.

- Use symmetrical building plans when possible since they typically provide better performance than “L” or irregularly shaped buildings when subjected to blast or seismic loading.
- Use hardened walls and adjacent slabs in the entrance lobby, loading dock, and mailrooms to withstand a hand-delivered package bomb, nominally a 25-50 lb (11-23 kg) explosive.
- Use a well-distributed lateral-load resisting mechanism in the horizontal floor plan, i.e., by using several shear walls around the plan of the building to improve overall seismic and blast resistance.
- Since the exterior facade is the occupant’s main protection from a blast, construct the exterior wall of a durable material, such as concrete masonry. If properly designed, the exterior wall can also assist in carrying the load of a damaged column.
- The amount of blast that enters a structure is directly proportional to the amount of openings in the structure. Limit door and window areas to protect the occupants. When this method is not aesthetically acceptable Use blast-resistant glazings, such as some glass unit masonry, Mylar, or other window films to minimize injury caused by flying glass.
- Avoid the use of reentrant corners and deep surface profiling. These can amplify blast pressures locally due to reflections of the shock wave, which combine with the initial blast to produce a greater pressure.

### RESISTANCE TO BALLISTICS

Bullet resistance can also have a high priority for many buildings, often more so than blast resistance. Most ballistic

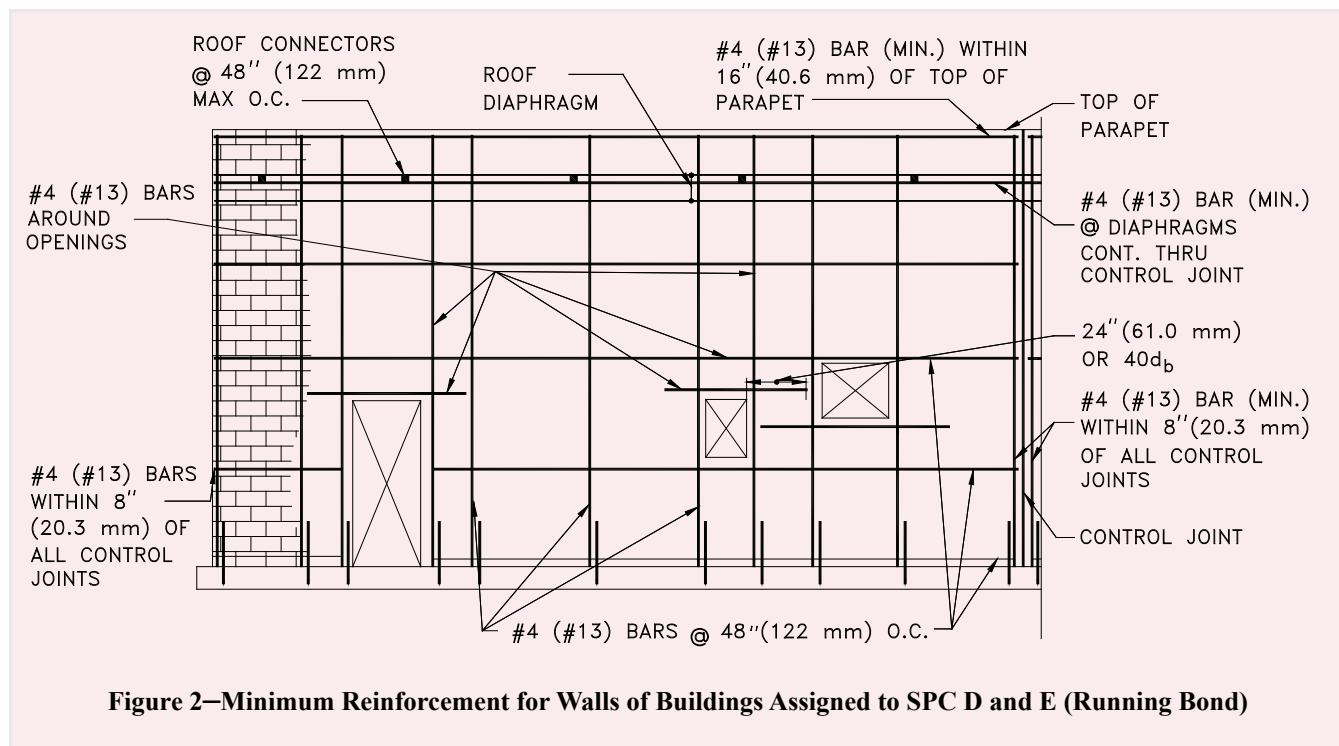

Figure 2—Minimum Reinforcement for Walls of Buildings Assigned to SPC D and E (Running Bond)

testing on concrete masonry walls was carried out during World War II to make sure that adequate protection was provided for transformers, switching stations, and other installations subject to sabotage.

Recommended constructions for bullet resistance are 8 in. (203 mm) solid or grouted concrete masonry walls or 12 in. (305 mm) hollow units with sand-filled cores. Both walls provided equal protection under test conditions (ref. 1). In no case did bullets penetrate the opposite face shell of the masonry when tested with high-powered rifles, revolvers, and machine guns.

Glass unit masonry products have been tested to Underwriters Laboratories (UL) standards for bullet resistance. Using bullet resistant glass block provides protection while allowing natural light into the building, and providing a more open atmosphere.

UL glazing components are tested for resistance against 9 mm, .357 magnum, .44 magnum, 30.06 rifle, 7.62 mm rifle, and 5.56 mm rifle ballistic attacks and are rated in eight levels. The various levels vary with type of ammunition, bullet velocity, and number of shots fired. In general, Level 1 provides a basic level of resistance with Level 8 providing the highest.

Solid glass unit masonry (8 x 8 x 3 in. thick) achieved UL Levels 1, 2, and 6 (3 shots from 9 mm, 3 shots from .357 magnum, and 5 shots from 9 mm with higher muzzle velocity than the 3 shot test respectively). Hollow glass block (8 x 8 x 4 in. thick) with a thickened,  $\frac{3}{4}$  in. (19 mm), face shell achieved a Level 1 rating. These ratings apply to glass unit masonry panels at least three units high by three units wide framed on all four sides and laid with Type S mortar (ref. 7).

## REFERENCES

1. *Concrete Masonry Walls for Protection Against Sabotage and Bomb Splinters*, Portland Cement Association, CP 51, 1942.
2. *Concrete Masonry Shear Walls*, TEK 14-7. National Concrete Masonry Association, 1992.
3. Ettouney, M., Rittenhouse, T., and Smilowitz, R. *Blast Resistant Design of Commercial Buildings*, Practice Periodical on Structural Design and Construction, February 1996.
4. Mays, G. C. and Smith, P. D., ed. *Blast Effects on Buildings*. Thomas Telford Publications, 1995.
5. *1994 NEHRP Recommended Provisions for Seismic Regulations for New Buildings*, Building Seismic Safety Council, 1994.
6. *The Oklahoma City Bombing: Improving Building Performance Through Multi-Hazard Mitigation*. Federal Emergency Management Agency Mitigation Directorate and American Society of Civil Engineers, August 1996.
7. *Report on Component Bullet-Resisting Materials, Glazing Material*. Underwriters Laboratory File BP8010, Volume 1, Sections 1 and 2, 1995.
8. *Section Properties of Concrete Masonry Walls*, TEK 14-1, National Concrete Masonry Association, 1993.
9. *Seismic Design Provisions for Masonry Structures*, TEK 14-18. National Concrete Masonry Association, 1996.
10. *Vulnerability Assessment of Federal Buildings*. U. S. Department of Justice, June 1995.