

National Concrete Masonry Association
 an information series from the national authority on concrete masonry technology

ARTICULATING CONCRETE BLOCK REVETMENT DESIGN— FACTOR OF SAFETY METHOD

TEK 11-12
 Pavers (2002)

Keywords: ACBs, articulating concrete block, design, factor of safety, erosion control, revetment

INTRODUCTION

Articulating concrete block (ACB) systems provide erosion protection to soil exposed to the hydraulic forces of moving water. ACB systems are a matrix of individual concrete blocks placed closely together to form an erosion-resistant overlay with specific hydraulic performance characteristics. Because it is composed of individual units, the ACB system can conform to minor changes in the subgrade without loss of intimate contact. Systems may be connected through geometric interlock and/or other components such as cables. Systems with openings in the blocks can typically be vegetated to provide a "green" channel and facilitate infiltration/exfiltration of channel moisture. Figure 1 illustrates a variety of ACB systems, but is not all-inclusive of available systems.

ACB units are concrete block produced in accordance with *Standard Specification for Materials and Manufac-*

ture of Articulating Concrete Block (ACB) Revetment Systems, ASTM D 6684 (ref. 1). Units must conform to minimum compressive strength, absorption and geometric specifications tested in accordance with *Standard Test Methods for Sampling and Testing Concrete Masonry Units and Related Units*, ASTM C 140 (ref. 2).

This TEK addresses the structural stability of ACB revetment systems as a function of site-specific open channel hydraulics and geomorphic characteristics of the revetment unit. This TEK does not address geotextile filter and/or subgrade filter design, minimum installation guidelines critical to the proper performance of ACB revetments, or minimum upstream or downstream toe treatments. These topics are covered in design manuals such as references 3 and 5.

FACTOR OF SAFETY METHOD

Similar to many riprap sizing methods, the Factor of

Safety method quantifies hydraulic stability of ACB systems using a "discrete particle" approach. The design method involves balancing the driving and resisting forces, including gravity, drag and lift as illustrated in Figure 2. In typical channel and spillway applications, failure due to sliding (slipping) of the ACB revetment along the bed is remote. The revetment system is more apt to fail as a result of overturning about the downstream edge of the ACB unit, or downstream corner point when the ACB unit is located on the side slope of a steep channel. For cases where the revetment is placed on steep side slopes (2H:1V or steeper), the design

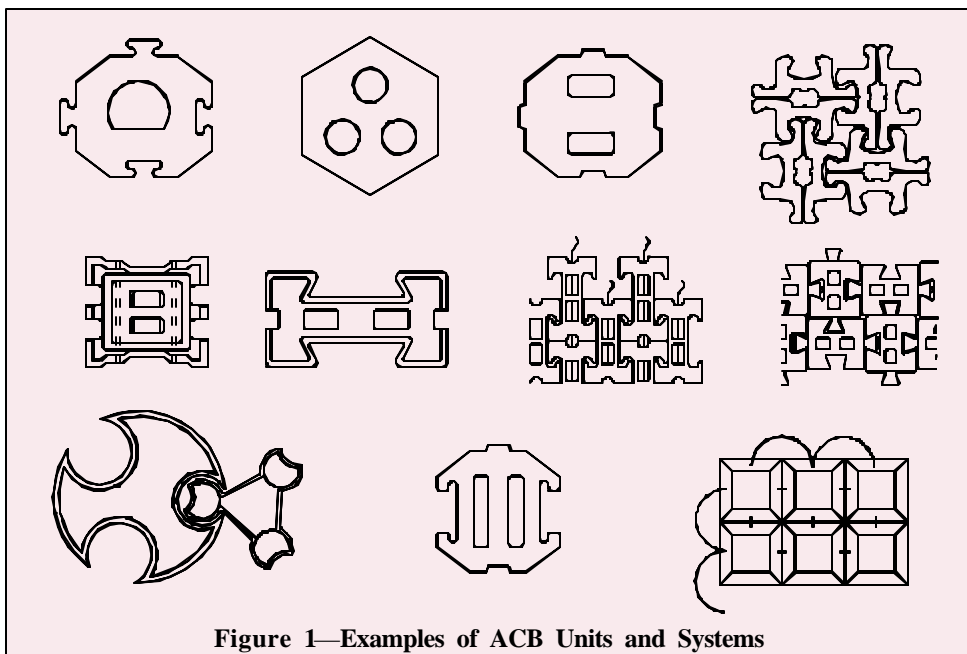

Figure 1—Examples of ACB Units and Systems

Table 1—Base Factor of Safety, SF_B

Example Application	SF_B
Channel bed or bank	1.2 – 1.4
Bridge pier or abutment	1.5 – 1.7
Overtopping spillway	1.8 – 2.0

Table 2—Consequence of Failure Multiplier, X_C

Consequence of Failure	X_C
Low	1.0 – 1.2
Medium	1.3 – 1.5
High	1.6 – 1.8
Extreme or loss of life	1.9 – 2.0

Table 3—Multiplier Based on Hydraulic Model, X_M

Hydraulic Model	X_M
Deterministic	1.0 – 1.3
Empirical or Stochastic	1.4 – 1.7
Estimates	1.8 – 2.0

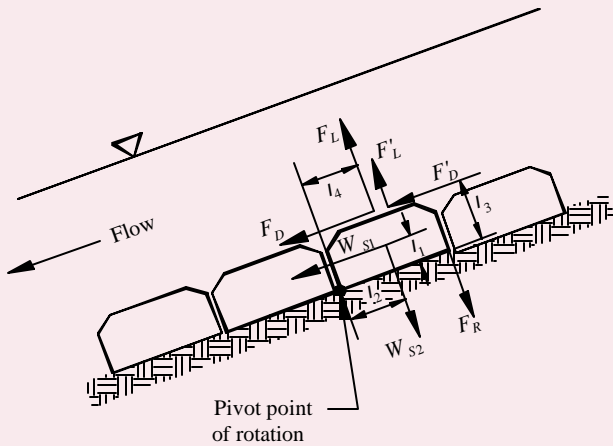

Overturning forces: $F_D, F_L, F'_D, F'_L, W_{s1}$

Restraining forces: F_R, W_{s2}

Figure 2—Moment Balance on ACB Unit (ref. 3)

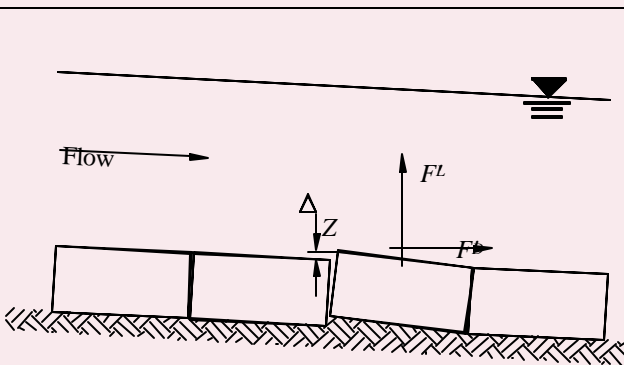

Figure 3—Schematic of Protruding Block

should evaluate the potential for slip shear failures along geosynthetic-ACB unit interfaces induced by hydraulic and gravitational forces.

Fundamental principles of open channel flow and rigid body mechanics are used along with hydraulic test results. The size and weight of the ACB units, as well as performance data from full-scale laboratory testing, are considered in evaluating the ratio of resisting to overturning moments (the “force balance” approach). This ratio defines the factor of safety against uplift. The design procedure accounts for additional forces applied to the unit when protrusions above the matrix occur, such as subgrade irregularities or due to improper placement (see Figure 3). Failure is defined as loss of intimate contact between the ACB unit and subgrade. The effects of cables or rods, vegetative root anchorage or mechanical anchorage devices are neglected.

Target Factor of Safety

The minimum acceptable factor of safety is determined from site-specific considerations such as the complexity of the hydraulic system, the risks associated with failure, and the uncertainty in the hydraulic analyses. Prudent engineering judgment should always be used to determine the target factor of safety, along with a balance between cost of conservatism and more sophisticated engineering analysis. An analytical approach to determine the target factor of safety is presented in reference 3 as:

$$SF_T = SF_B X_C X_M$$

where Tables 1-3 list recommended minimums for each variable in the equation above.

Hydraulic Considerations

The main hydraulic variable in ACB stability design is the total hydraulic load (or bed shear stress) created by a varying discharge within a fixed geometric cross-section. The ratio of designed average cross-sectional bed shear to the ACB's critical shear value (obtained from testing) is used, in part, for practical analysis and evaluation of ACB stability. The cross-section averaged bed shear stress, τ_o , can be calculated for design using a simple equation (ref. 11):

$$\tau_o = \gamma R S_f$$

τ_o is applied over the channel boundary, regardless of channel lining. Shear stress is a function of the hydraulic radius and the slope of the energy line (for the simplest case - the bed slope), both defined by channel geometry and flow conditions.

The cross-section averaged bed shear stress is suitable for uniform flow conditions such as those found in long straight reaches of open channels with uniform cross section. It may be determined using simplified model approaches, such as the Manning equation or the HEC-2 model (ref. 9). For cases involving bends, confluences, constrictions and flow obstructions, more sophisticated hydraulic modeling is generally appropriate, such as a two-dimensional model

which can evaluate time-dependent flow conditions or complex geometry (ref. 8).

Design velocity is often determined using the Manning Equation for steady uniform flow as follows (ref. 11):

$$Q = (1.486/n) A R^{2/3} S_f^{1/2} \quad \text{[inch-pound]}$$

$$Q = (1/n) A R^{2/3} S_f^{1/2} \quad \text{[metric]}$$

An iterative process is used to determine the flow depth y_o , because both the area and hydraulic radius are functions of y_o . Cross-sectional averaged velocity of flow is then defined as $V = Q/A$. As noted previously, complex hydraulic systems require sophisticated modeling to determine averaged velocity.

The cross-section averaged bed shear stress and cross-sectional averaged velocity should be determined by a design professional familiar with hydraulic design practices.

ACB Revetment Considerations

Manufacturers of ACB systems provide performance data from full-scale tests performed in accordance with Federal Highway Administration guidelines (ref. 6). This data provides the critical shear stress, τ_c , and is based on specific flow conditions and ACB system characteristics. The manufacturer should specify whether the critical shear stress is for a unit on a horizontal surface or on an inclined surface. Values for a unit on a horizontal surface are commonly specified. It is important that the designer consider the full-scale test configuration and hydraulic conditions used to derive the critical shear stress on a horizontal surface.

Testing involves the construction of a full-scale test embankment that is subsequently exposed to hydraulic load until failure—defined as the local loss of intimate contact between the ACB unit and the subgrade it protects. A schematic of a typical flume is illustrated in Figure 4.

ACB system stability is evaluated by summing the driving and resisting moments about the toe of an individual ACB unit. The inter-block restraint, F_R , is ignored, as is any contribution from cables or anchorages (see Figure 2).

ACB placement or subgrade irregularities can result in one unit protruding above the ACB matrix, as shown in Figure

Table 4—Design Equations for ACB Systems (ref. 3)

$$SF = \frac{(\ell_2 / \ell_1) a_q}{\sqrt{1 - a_q^2} \cos b + h_1 (\ell_2 / \ell_1) + \frac{(\ell_3 F'_D \cos d + \ell_4 F'_L)}{\ell_1 W_S}}$$

$$\delta + \beta + \theta = 90^\circ \text{ or } \pi/2 \text{ radians}$$

where:

$$b = \arctan \left(\frac{\cos(\mathbf{q}_0 + \mathbf{q})}{(\ell_4 / \ell_3 + 1) \frac{\sqrt{1 - a_q^2}}{h_0 (\ell_2 / \ell_1)} + \sin(\mathbf{q}_0 + \mathbf{q})} \right)$$

$$\mathbf{q} = \arctan \left(\frac{\sin \mathbf{q}_0 \cdot \cos \mathbf{q}_1}{\sin \mathbf{q}_1 \cdot \cos \mathbf{q}_0} \right) = \arctan \left(\frac{\tan \mathbf{q}_0}{\tan \mathbf{q}_1} \right)$$

$$\eta_o = \tau_{des} / \tau_c$$

$$h_1 = \left(\frac{\ell_4 / \ell_3 + \sin(\mathbf{q}_0 + \mathbf{q} + \mathbf{b})}{\ell_4 / \ell_3 + 1} \right) h_0$$

$$a_q = \sqrt{\cos^2 \mathbf{q}_1 - \sin^2 \mathbf{q}_0}$$

$$F'_L = F'_D = 0.5 \Delta Z b_u \rho V_{des}^2$$

$$W_S = W \cdot \left(\frac{S_C - 1}{S_C} \right)$$

Note: The equations cannot be solved for $\mathbf{q}_1 = 0$ (i.e., division by 0); therefore, a negligible side slope must be entered for the case of $\mathbf{q}_1 = 0$.

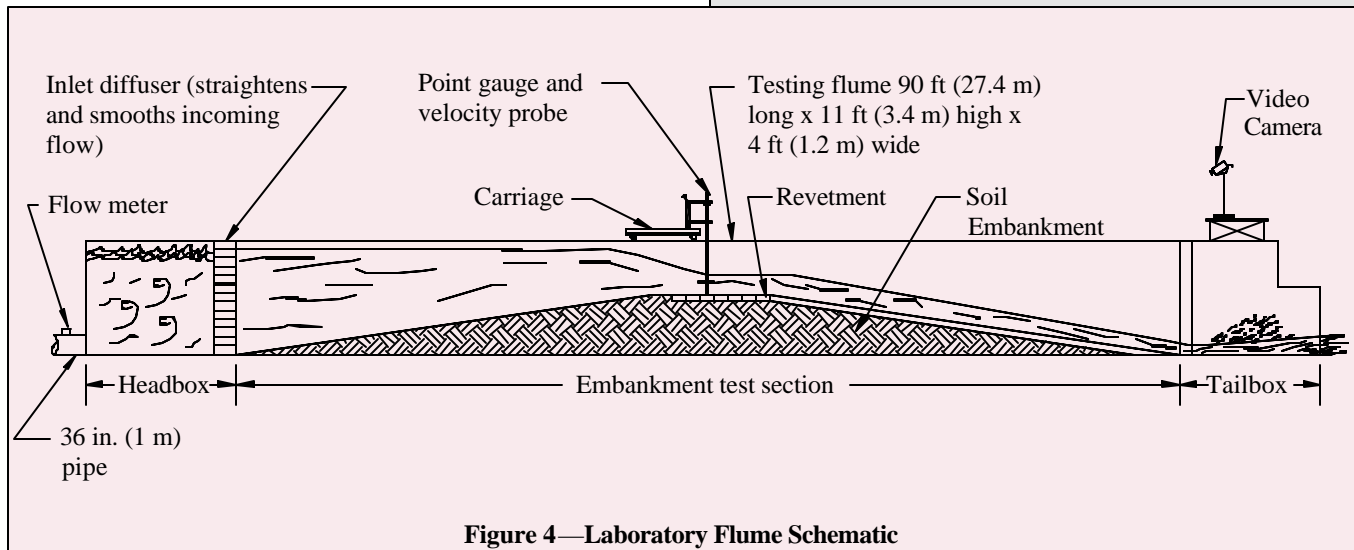
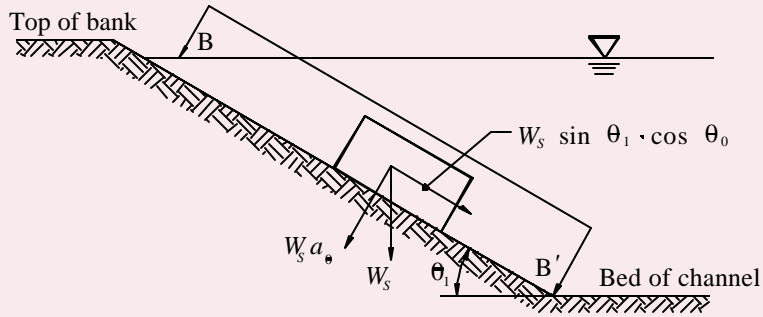
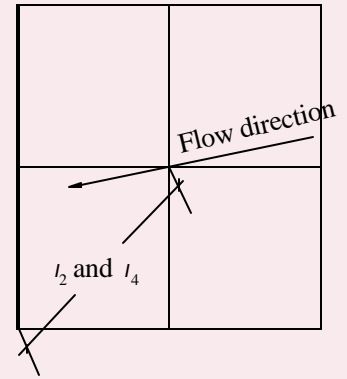

Figure 4—Laboratory Flume Schematic



(a) Channel cross-section



(b) Plan view of unit

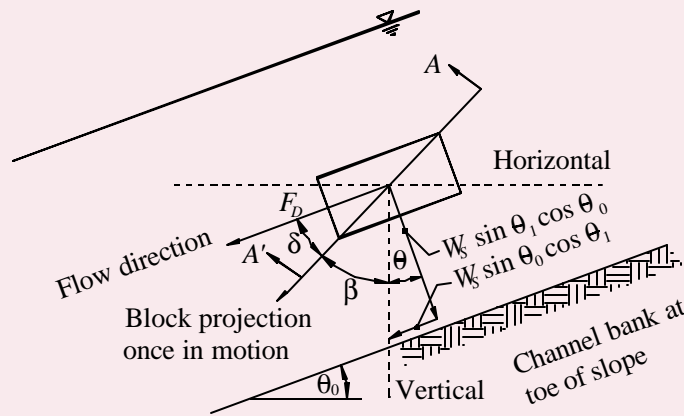

(c) Section B - B', view normal to plane of channel bank

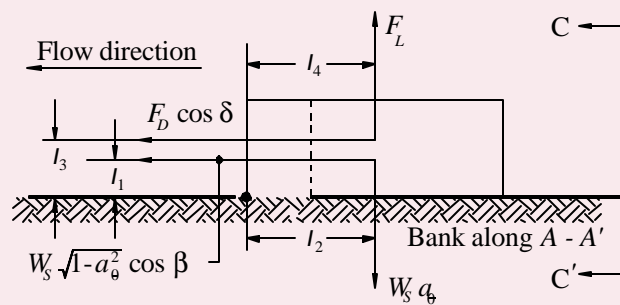

(d) Section A - A'

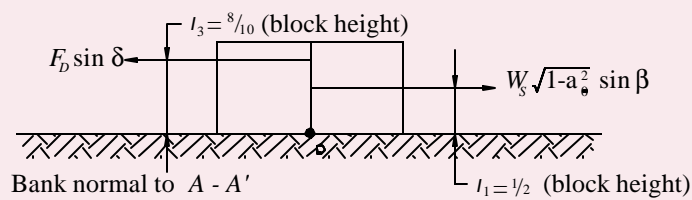

(e) Section C - C' (flow direction normal to page)

Figure 5—ACB Unit Design Variables

3. The protrusion height, ΔZ , is a function of installation practice and block-to-block interface, and is often assumed to be $1/4$ to $1/2$ in. (6 to 13 mm). However, the designer must consider site-specific conditions and adjust ΔZ as required. The lift force, F'_L , resulting from the protrusion is conservatively assumed equal to the drag force, F'_D .

The factor of safety against loss of intimate contact is considered to be a function of design bed shear stress, critical shear stress, channel geometry and ACB unit geometry and weight. Figure 5 illustrates unit moment arms based on unit geometry.

The safety factor for a single ACB unit is determined from the ratio of restraining moments to overturning moments. Considering the submerged unit weight, W_s , unit moment arms and drag and lift forces, the safety factor, SF is defined as (ref. 3):

$$SF = \frac{\ell_2 W_s a_q}{\ell_1 W_s \sqrt{1 - a_q^2} \cos \mathbf{b} + \ell_3 F_D \cos \mathbf{d} + \ell_4 F_L + \ell_3 F'_D \cos \mathbf{d} + \ell_4 F'_L}$$

Dividing by $\ell_1 W_s$ and substituting terms, the equation for SF resolves to that presented in Table 4. Table 4 also outlines the calculations necessary for determining factor of safety.

DESIGN EXAMPLE

A trapezoidal channel section with 3H:1V side slopes ($Z = 3$, $\theta_1 = 18.4^\circ$) and a base width b of 15 ft (4.6 m) requires stabilization. The 100-year design discharge is 450 ft³/s (12.7 m³/s), and the channel slope S_o is 0.03 ft/ft (0.03 m/m) ($\theta_0 = 1.72^\circ$). The channel has a uniform bed and no flow obstructions (i.e. confluences, bends or changes in geometry). Manning's n is specified as 0.035. Based on design conditions, the energy grade line S_f is assumed equal to the channel slope S_o .

Step 1 Determine flow depth and cross-sectional averaged velocity:

$$Q = 1.486/n A R^{2/3} S_f^{1/2}$$

$$A = by_o + Zy_o^2, \text{ cross-sectional flow area}$$

$$P = b + 2(y_o^2 + (Zy_o)^2)^{1/2}, \text{ wetted perimeter}$$

$$R = A/P, \text{ hydraulic radius}$$

By iteration, the flow depth y_o is determined to be 2.1 ft (0.6 m).

$$V = Q/A = 450 \text{ ft}^3/\text{s} / 44.73 \text{ ft}^2 = 10.1 \text{ ft/s} (3.1 \text{ m/s})$$

Step 2 Calculate design shear stress:

$$\tau_{\text{des}} = \gamma R S_f = (62.4 \text{ lb/ft}^3)(1.582 \text{ ft})(0.03 \text{ ft/ft}) = 2.96 \text{ psf} (0.14 \text{ kPa})$$

Step 3 Select target factor of safety:

Assuming a base factor of safety SF_B equal to 1.3 for a channel bed, a low consequence of failure ($X_C = 1.2$), and an empirical hydraulic model ($X_M = 1.5$), the target factor of safety is:

$$SF_T = SF_B X_C X_M = (1.3)(1.2)(1.5) = 2.34$$

Step 4 Select potential ACB product and obtain geomorphic and critical shear stress data:

The proposed ACB manufacturer specifies a critical shear stress τ_c for the unit on a horizontal surface of 30 psf (1.4 kPa), submerged unit weight of 35 lb (16 kg) and dimensions of 15 (w) x 18 (l) x 5 (h) in. (381 x 457 x 127 mm).

Step 5 Calculate factor of safety against incipient unit movement:

Given;

$$W_s = 35 \text{ lb} (16 \text{ kg})$$

$$b_u = 1.5 \text{ ft} (460 \text{ mm})$$

$$\tau_c = 30 \text{ psf} (1.4 \text{ kPa})$$

$$\eta_0 = 2.96/30 = 0.0987$$

and determining the following geometrically (see Figure 5);

$$l_1 = 5/2/12 = 0.208 \text{ ft} (64 \text{ mm})$$

$$l_2 = l_4 = \sqrt{(18)^2 + (15)^2} / 2/12 = 0.976 \text{ ft} (297 \text{ mm})$$

$$l_3 = 0.8(5)/12 = 0.333 \text{ ft} (101 \text{ mm})$$

and assuming (see discussion);

$$\Delta Z = 0.0417 \text{ ft} (13 \text{ mm})$$

the following are calculated using the equations in Table 4:

$$F'_L = F'_D = 6.14 \text{ lb} (0.03 \text{ kN})$$

$$a_\theta = 0.948$$

$$\theta = 5.14^\circ$$

$$\beta = 19.4^\circ$$

$$\eta_1 = 0.0847$$

$$\delta = 65.4^\circ$$

$$SF = 2.72$$

Because the calculated factor of safety exceeds the target, the proposed ACB system is stable against loss of intimate contact.

NOTATIONS:

A = cross-sectional flow area, ft² (m²)

a_q = projection of W_s into subgrade beneath block (Table 4)

b = width of channel base, ft (mm)

b_u = width of ACB unit in the direction of flow, ft (mm)

F_D = drag force, lb (kN)

F'_D = additional drag forces, lb (kN)

F_L = lift force, lb (kN)

F'_L = additional lift forces, lb (kN) (Table 4)

F_R = inter-block restraint, lb (kN)

l_x = block moment arms, ft (mm)

n = Manning's roughness coefficient

Q = design discharge, ft³/s (m³/s)

R = hydraulic radius (A /wetted perimeter), ft (m)

S_C = specific gravity of concrete (assume 2.1)

S_f = energy grade line, ft/ft (m/m)

S_o = bed slope, ft/ft (m/m)

SF = calculated factor of safety (Table 4)

SF_B = base factor of safety (Table 1)

SF_T = target factor of safety

V = cross-sectional averaged flow velocity, ft/s (m/s)
 W = weight of block, lb (kg)
 W_s = submerged weight of block, lb (kg) (Table 4)
 W_{s1} = gravity force parallel to slope, lb (kN)
 W_{s2} = gravity force normal to slope, lb (kN)
 X_C = multiplier based on consequence of failure (Table 2)
 X_M = multiplier based on hydraulic model uncertainty (Table 3)
 y_o = flow depth, ft (m)
 Z = horizontal to vertical ratio of channel side slope
 β = angle of block projection from downward direction, once in motion, degrees or radians
 γ = unit weight of water, 62.4 pcf (1,000 kg/m³)
 ΔZ = height of block protrusion above ACB matrix, ft (mm)
 δ = angle between drag force and block motion, degrees or radians
 η_o = stability number for a horizontal surface (Table 4)
 η_1 = stability number for a sloped surface (Table 4)
 θ = angle between side slope projection of W_s and the vertical, degrees or radians (Table 4)
 θ_o = channel bed slope, degrees or radians
 θ_1 = channel side slope, degrees or radians
 ρ = mass density of water, 1.94 slugs/ft³ (1,000 kg/m³)
 τ_c = critical shear stress for block on a horizontal surface, lb/ft² (kPa)
 τ_{des} = design shear stress, lb/ft² (kPa)
 τ_o = cross-section averaged bed shear stress, lb/ft² (kPa)

REFERENCES

1. *Standard Specification for Materials and Manufacture of Articulating Concrete Block (ACB) Revetment Systems*, ASTM D 6684-01. ASTM International, 2001.
2. *Standard Test Methods for Sampling and Testing Concrete Masonry Units and Related Units*, ASTM C 140-01^{ae1}. ASTM International, 2001.
3. *Design Manual for Articulating Concrete Block Systems*. Harris County Flood Control District, Houston, Texas, 2001.
4. *Hydraulic Engineering*. Federal Highway Administration Hydraulic Engineering Circular No. 23. Available through the National Technical Information Service.
5. *Design of Roadside Channels with Flexible Lining*. Federal Highway Administration Hydraulic Engineering Circular No. 15. Available through the National Technical Information Service.
6. Clopper, P. E. and Y. Chen. *Minimizing Embankment Damage During Overtopping Flow*, Technical Report FHWA RD-88-181. Federal Highway Administration, 1988.
7. Clopper, P. E. *Hydraulic Stability of Articulated Concrete Block Revetment Systems During Overtopping Flow*, Technical Report FHWA RD-89-199. Federal Highway Administration, 1989.
8. *RMA-2V Version 4.35*. United States Army Corps of Engineers. USACE Waterways Experiment Station, 1997.
9. *HEC-RAS Version 2.2*. United States Army Corps of Engineers. USACE Hydrologic Engineering Center, 1998.
10. *Articulated Concrete Block for Erosion Control*, TEK 11-9A. National Concrete Masonry Association, Herndon, Virginia, 1999.
11. Morris, H. M. and J. Wiggert. *Applied Hydraulics in Engineering*, Second Edition, James Wiley & Sons, 1972.