

National Concrete Masonry Association
an information series from the national authority on concrete masonry technology

SPECIFICATIONS FOR CONCRETE MASONRY ROOF PAVERS

TEK 2-5A
Unit Properties (1999)

Keywords: ASTM Standards, absorption, ballasted roofs, compressive strength, durability, flexural strength, interlocking roof pavers, roof ballast, roof pavers, testing

INTRODUCTION

Concrete roof pavers provide resistance to wind uplift and surface protection for roofing membranes. Concrete roof paver systems are installed over flat roofs and allow melting snow and ice, or rain water to drain from below the roof paver surface. Ballast weight of the concrete roof paver system is designed to resist uplift forces from the entire range of design wind speeds. Concrete roof pavers also provide a durable wearing surface for roof maintenance and repair operations.

Specifications for concrete roof pavers included herein specify the physical requirements to ensure field performance. Also presented are methods of sampling and testing pavers to demonstrate compliance with these requirements.

CONCRETE ROOF PAVER SYSTEMS

Concrete roof paver systems are categorized as interlocking or non-interlocking. Interlocking systems distribute uplift forces to adjacent pavers by a tongue and groove edge connection or by a mechanical interlock between units. Non-interlocking systems resist uplift by the ballast weight of individual paver units.

CONCRETE ROOF PAVER UNITS

Roof pavers are exposed to severe weather conditions due to their horizontal installation over flat or low slope roofs. In cold weather regions, roof pavers can be routinely subjected to freezing and thawing in a saturated condition. Typically these units will also be required to support foot traffic, loaded wheelbarrows, and other equipment without damaging the roofing membrane and insulation. These conditions require that concrete roof pavers be manufactured to specific criteria. The following specification is recommended to ensure a product of consistent quality.

DESIGN AND EXECUTION

In addition to the physical characteristics of the roof paver units themselves, parameters for design of concrete roof paver systems include the following:

- Basic wind speed at building site
- Building height
- Parapet height
- Wind gust factors
- Adjacent structures and terrain features to account for obstructions in the area
- Load capacity of the roof structure
- Roof discontinuities
- Roof slope
- Weight of the units

Roof structures must be designed to support the dead weight of roof paver systems. Where roof pavers are installed over existing roofs, it is important to evaluate the structural adequacy of the existing roof to support the roof pavers.

Since modern roof paver systems usually contain integral drainage grooves, consideration should be given to their orientation parallel to the roof slope, min. $\frac{1}{4}$ " per foot (20 mm/m), towards roof drains. See Figure 1 for a typical concrete paver roof installation.

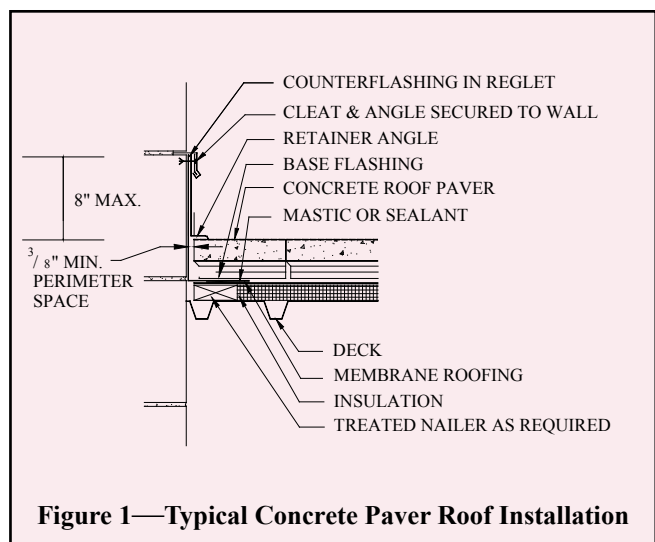

Figure 1—Typical Concrete Paver Roof Installation

SPECIFICATION FOR CONCRETE ROOF PAVERS

1. Scope

1.1 This specification covers concrete roof pavers made from portland cement, water, and mineral aggregates, with or without the inclusion of other materials, for use as roof ballast and protection of roof membranes.

Note 1 – The design of roof ballast systems for resisting wind uplift is beyond the scope of this standard. Building codes and other standards should be consulted in designing for wind uplift resistance.

1.2 Concrete roof pavers covered by this specification are made from lightweight or normal weight aggregates, or both.

1.3 The values stated in inch-pound units are to be regarded as the standard. The values given in parentheses are for information only.

2. Referenced documents

- 2.1 ASTM Standards:
 - C33 Specification for Concrete Aggregates
 - C140 Methods of Sampling and Testing Concrete Masonry Units
 - C150 Specification for Portland Cement
 - C331 Specification for Lightweight Aggregates for Concrete Masonry Units
 - C595/C595M Specification for Blended Hydraulic Cements
 - C618 Specification for Fly Ash and Raw or Calcined Natural
 - Pozzolan for Use as a Mineral Admixture in Portland Cement Concrete
 - C989 Specification for Ground Granulated Blast-Furnace Slag for Use in Concrete and Mortars
 - C1157/C1157M Performance Specification for Blended Hydraulic Cement
 - C1262 Standard Test Method for Evaluating the Freeze-Thaw Durability of Manufactured Concrete Masonry Units and Related Concrete Units

3. Materials

3.1 Cementitious Materials - Materials shall conform to the following applicable specifications:

- 3.1.1 Portland Cement - specification C 150.
- 3.1.2 Modified Portland Cement - Portland Cement conforming to specification C 150 modified as follows:

3.1.2.1 Limestone - Limestone, with a minimum 85% calcium carbonate (CaCO₃) content, shall be permitted to be added to the cement, provided the requirements of Specification C 150 as modified are met:

- (1) Limitation on Insoluble Residue - 1.5%
- (2) Limitation on Air Content of Mortar - Volume percent, 22% max.
- (3) Limitation on Loss on Ignition - 7%.

3.1.3 Blended Cements - Specification C 595/C 595M or C 1157/C 1157M.

3.1.4 Pozzolans - Specification C 618

3.1.5 Blast Furnace Slag - Specification C 989

3.2 Aggregates - Aggregates shall conform to the following specifications, except that grading requirements shall not necessarily apply:

3.2.1 Normal Weight Aggregates - Specification C 33.

3.2.2 Lightweight Aggregates - Specification C 331.

3.3 Other Constituents - Air-entraining agents, coloring pigments, integral water repellents, finely ground silica, and other constituents shall be previously established as suitable for use and shall conform to applicable ASTM Standards or, shall be shown by test or experience satisfactory to the purchaser to be not detrimental to the durability of the units.

4. Physical Requirements

4.1 At the time of delivery to the purchaser, all units shall conform to the requirements prescribed in Table 1 and shall have a minimum net area average compression strength (average of 3 units) of 3000 psi (20.68 MPa)

Concrete Density lb/ft ³ /(kg/m ³)	Maximum Water Absorption lb/ft ³ /(kg/m ³) (average of 3 units)
95 (1522) or less	15 (240)
over 95 to 115 (1522 to 1842)	13 (208)
115 (1842) or more	10 (160)

with no individual unit compressive strength less than 2600 psi (17.93 MPa) when tested in accordance with Section 7.2

4.2 Resistance to Flexural Load - The average resistance to flexural load for three paver units shall exceed 350 lb (1557 N) and resistance to flexural load of each individual unit shall exceed 280 lb (1246 N) when tested in accordance with Section 7.2.

4.3 Ballast Weight—Requirements for ballast weight per unit area shall be specified separately.

4.4 Freeze-Thaw Durability—In areas where repeated freezing and thawing under saturated conditions occur, freeze-thaw durability shall be demonstrated by test or by proven field performance that the concrete roof paver units have adequate durability for the intended use. When testing is required by the specifier to demonstrate freeze-thaw durability, the units shall be tested in accordance with the requirement of Section 7.3.

4.4.1 Specimens shall comply with either of the following: (1) the weight loss of each of five test specimens at the conclusion of 100 cycles shall not exceed 1% of its initial weight; or (2) the weight loss of each of four or five test specimens at the conclusion of 150 cycles shall not exceed 1.5% of its initial weight.

Note 2 – This standard does not include criteria for large hail stone impact. Where

required, these criteria should be specified by the purchaser.

5. Permissible Variations in Dimension and Weight

5.1 Overall dimensions for width, height, and length shall not differ by more than $\pm 1/8$ in. (3.2 mm) from the specified standard dimensions.

5.2 Ballast weight shall not differ by more than ± 2.0 lb/ft² (9.7 kg/m²) from the specified weight.

Note 3 - Standard dimensions of units are the manufacturer's designated dimensions.

6. Finish and Appearance

6.1 All units shall be sound and free of cracks or other defects that would interfere with the proper placement of the unit or would significantly impair the strength or permanence of the construction. Minor cracks incidental to the usual method of manufacture or minor chipping resulting from customary methods of handling in shipment and delivery, are not grounds for rejection.

6.2 Five percent of a shipment containing chips not larger than 1 in. (25.4 mm) in any dimension, or cracks not wider than 0.02 in. (0.5 mm) and not longer than 25% of the nominal height of the unit is permitted.

6.3 The color and texture of units shall be specified by the purchaser. The finished surfaces that will be

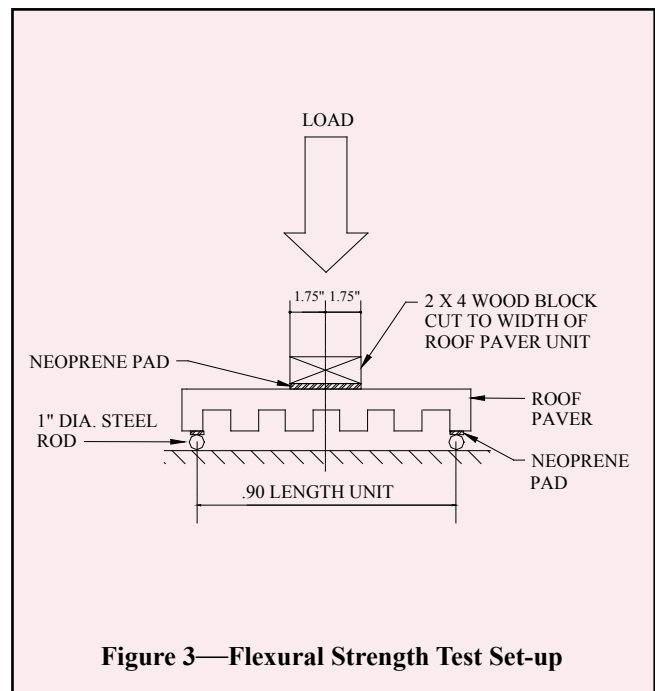
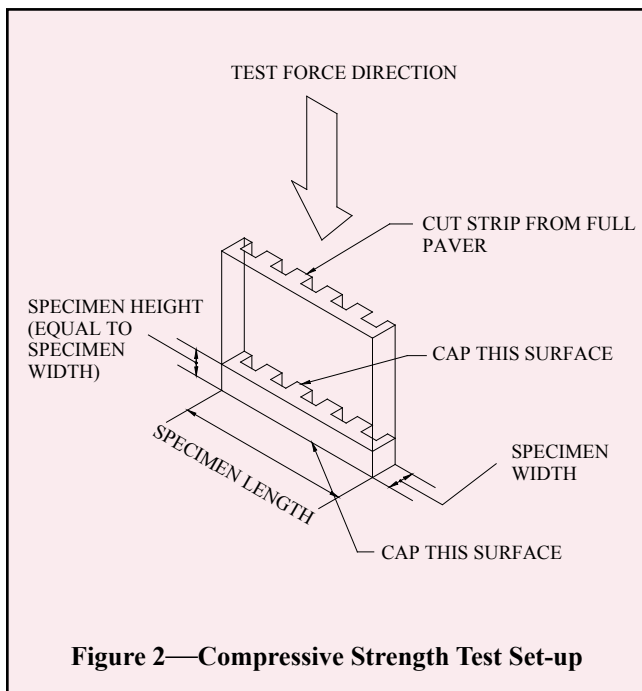

exposed in place shall conform to an approved sample consisting of not less than four units, representing the range of texture and color permitted.

7. Sampling and Testing

7.1 The purchaser or authorized representative shall be accorded proper facilities to inspect and sample the units at the place of manufacture from the lots ready for delivery.

7.2 Sample and test units for compressive strength, flexural load, absorption, and dimensional tolerance in accordance with Test Methods C 140.

7.3 When required, sample and test five specimens for freeze-thaw durability in water in accordance with C 1262. Freeze-thaw durability shall be based on tests of units made with the same materials, concrete mix design, manufacturing process, and curing method, conducted not more than 24 months prior to delivery.

8. Compliance

8.1 If a sample fails to conform to the specified requirements, the manufacturer shall be permitted to remove units from the shipment. A new sample shall be selected by the purchaser from the remaining units from the shipment with a similar configuration and dimension and tested at the expense of the manufacturer. If the second sample meets the specified requirements, the remaining portion of the shipment represented by the sample meets the specified requirements. If the second sample fails to meet the specified requirements, the remaining portion of the shipment represented by the sample fails to meet the specified requirements.

Note 4 - Unless otherwise specified in the purchase order, the cost of the test is typically borne as follows: (1) if the results of the tests show that the units do not conform to the requirements of this specification, the cost is typically borne by the seller; (2) if the results of the tests show that the units conform to the specification requirements, the cost is typically borne by the purchaser.

NCMA and the companies disseminating this technical information disclaim any and all responsibility and liability for the accuracy and the application of the information contained in this publication.